

12. It is essential that the BOSSMIX range of thermostatic mixing valves fail-safe should not be installed in situations where there is a possibility of the valve being deprived of water or where demands for water are greater than the actual stored supplies.
13. To ensure that the performance levels of the BOSSMIX range of thermostatic mixing valves valve are maintained (in the event of cold water failure), the temperature of the hot water supply at the point of entry to the BOSSMIX range of thermostatic mixing valves valve must be a minimum of 10°C above the commissioned mixed water discharge temperature.
14. The BOSSMIX range of thermostatic mixing valves fail-safe products must not be subject to any extreme temperature variations either during the installation or under normal operating conditions.

COMMISSIONING

IMPORTANT - The following instructions must be read and understood prior to the commissioning of a The BOSSMIX range of thermostatic mixing valves. If under any circumstances there are aspects to the installation / system which do not comply with the specification laid down, the valve **MUST NOT** be put into operation until the system / installation complies with our specification. However if all these conditions are met, proceed to set the temperature as follows;

1. Ensure the designation of thermostatic mixing valves matches the application and that the system is thoroughly cleaned and free from any debris prior to the commissioning of the BOSSMIX range of thermostatic mixing valves. The supply temperatures are within the valves operating range
2. The commissioning of the temperatures must be carried out using a suitably calibrated thermometer – preferably a digital thermometer The sensing part of the thermometer probe must be fully submerged in the water when testing.
3. Each Valve must be commissioned taking into consideration any fluctuations, which may occur within the system due to simultaneous demands. It is advisable that any outlets which are connected to the same supply as the mixing valve is connected to, open during the setting of the mixed water temperature. During commissioning it is advisable to ensure that the water temperatures are established before any attempt to commission.
4. Once the supply temperatures are stable and the normal operating conditions are established, the valve can be commissioned, due to the unique design of the head – the temperature setting can be adjusted by removing the head from the valve body and reversing the head onto the temperature adjustment spindle. We suggest that the following sequence is followed when commissioning the valve;
 - 4.1 Set the mixed water temperature to the required temperature.
 - 4.2 Measure and record the temperature of the hot and cold water supplies at the connection to the valve.
 - 4.3 Measure and record the temperature of the water discharging from the valve.
 - 4.4 Isolate the cold water supply to the valve and monitor the mixed water temperature.
 - 4.5 Measure and record the maximum mixed water temperature and the final temperature. The final temperature found during the test should not exceed the values quoted
 - 4.6 Record all the equipment used during the commissioning.
 - 4.7 The mixed water temperature at the terminal fitting must never exceed 2°C above set temperature.
 - 4.8 The maximum mixed water supply temperature at the terminal fitting should not exceed 46°C.

5. Once the desired temperature is established remove the cap and secure the temperature spindle with the locking ring and replace the cap into its original position to prevent tampering by unauthorized persons. For shower and bath product refer to the relevant section of the instructions. Ensure that the application, in which the valve will be used in, is appropriate for the approved designation.
6. The above information must be recorded and updated on every occasion when any work is carried out on the valve.

IN SERVICE TESTING

The BOSSMIX range of thermostatic mixing valves should be tested against the original set temperature results once a year. When testing is due the following performance checks shall be carried out.

1. Measure the mixed water temperature at the outlet.
2. Carry out the cold fail-safe shut off test by isolating the cold water supply to the BOSSMIX RANGE OF THERMOSTATIC MIXING VALVES, wait for five seconds if water is still flowing check that the temperature is below 46°C for bath fill and 43°C for showering
3. If there is no significant change to the set outlet temperature ($\pm 2^\circ\text{C}$ or less change from the original settings) and the fail-safe shut off is functioning, then the valve is working correctly and no further service work is required.
4. If the BOSSMIX range of thermostatic mixing valves has been adjusted or serviced it must be re-commissioned and re-tested in accordance with these instructions.

PROBLEM SOLVING

The following details are supplied for on site queries, should you require any further assistance our technical department can be contacted directly on 0870 112 1597.

- 1 **HOT WATER AT THE COLD TAPS**
 - i. Operation of the insert check valves is hindered, check the valve is seated correctly.
 - ii. Check Valves not fitted.
 - iii. Unbalanced hot/cold supply pressure.
- 2 **FLUCTUATING MIXED WATER TEMPERATURE**
 - i. Erratic supply temperatures at the inlets of the valve.
 - ii. Starvation of the water supplied at the inlets of the valve.
 - iii. Incorrect commissioning of the valve.
- 3 **ERRATIC FLOW**
 - i. Insufficient water supplies.
 - ii. Fluctuations in the supply pressures/temperatures.
 - iii. Adverse effect created by other draw off points on the system.
- 4 **NO FLOW/REDUCED FLOW FROM VALVE**
 - i. In line filters are blocked.
 - ii. Insufficient supply pressure.
 - iii. Debris obstructing valve operation.
 - iv. Valve requires servicing (Servicing kits available on request)
- 5 **VALVE DOES NOT FAIL SAFE WHEN TESTED**
 - i. Installation not in accordance with our recommendations.
 - ii. The minimum temperature differential not achieved.
 - iii. Internal mechanism hindered by debris.

BOSSMIX™



Installation and Maintenance Instructions

The following information is required for use when the BOSSMIX range of thermostatic mixing valves is used in a TMV2 Applications under the requirements of BS EN 1111: 1999 "Sanitary tapware – Thermostatic Mixing Valve (PN 10) – General Technical Specification and BS EN 1287: 1999 "Sanitary tapware. Low pressure thermostatic mixing valves. General technical specifications.

INTRODUCTION

The BOSSMIX range of thermostatic mixing valves have been specifically designed and manufactured to meet the requirements of BS EN 1111: 1999 and BS EN 1287: 1999 and TMV2 Type Scheme. The valve has been independently tested and approved as a TYPE 2 valve under the Buildcert TMV2 scheme by the WRC Testing & Evaluation Center.

TECHNICAL SPECIFICATION / CONDITIONS FOR USE TMV2 VALVES

	High Pressure BS EN 1111	Low Pressure BS EN 1287
Max Static Pressure	10 Bar	10 Bar
Flow Pressure, Hot & Cold	0.5 - 5 Bar	0.1-1.0 Bar
Hot Supply Temperature	55°C - 65°C	55°C - 65°C
Cold Supply Temperature	≤25°C	≤25°C
Temperature Stability	±2°C	±2°C
Min. Temp Differential (Mix to Hot) for fail-safe	10°C	10°C
Max. Pressure Inlet Differential	5:1	5:1



NOTE: Valves operating outside these conditions cannot be guaranteed by the Scheme to operate as Type 2 valves.



THE BSS GROUP PLC

Fleet House, Lee Circle, Leicester, LE1 3QQ
Tel: 0116 2623232 Fax: 0116 2531343
www.bssgroup.com

APPROVALS

 Buildcert Scheme Approval Number Details Available on Request
 WRAS Scheme Approval Number Details Available on Request

DIMENSIONS

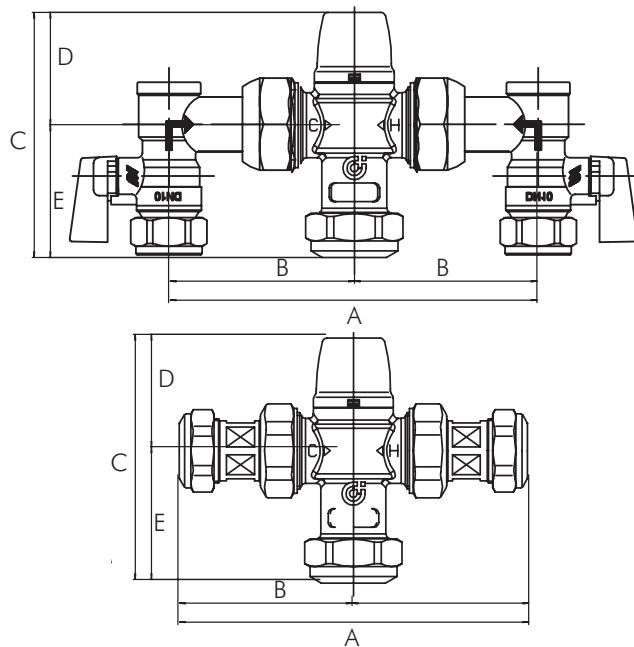

Code	A mm	B mm	C mm	D mm	E mm	Weight Kg
BMTMV2 15mm	135	67.5	105	49	56	0.50
BMTMV2 22mm	150	75	106	49	57	0.60
TMV2 15mm Care	191	96	105	49	56	0.65
TMV2 22mm Care	197	99	106	49	56	0.70

FLOWRATE

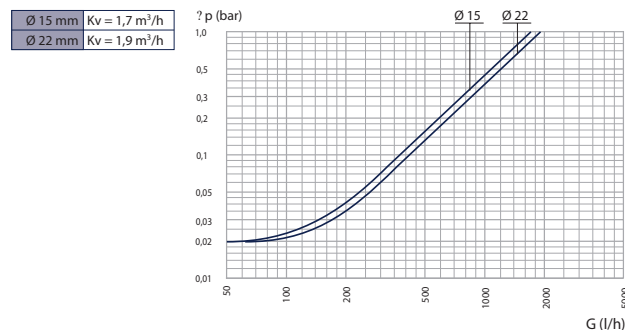

APPLICATION

The valves designation of use, LP if tested against BS EN 1287, HP if tested against BS EN 1111 and HP and LP if tested against both standards.

The BOSSMIX range of thermostatic mixing valves have been independently tested by WRc and certified as meeting the requirements of the BS EN 1111:1999 and BS EN 1287: 1999 under the TMV2 Scheme as being suitable for use on the following designations.

NOTE: Applies to HP Installations Only

If a water supply is fed by gravity then the supply pressure should be verified to ensure the conditions of use are appropriate for the valve. The installation of thermostatic mixing valves must comply with the requirements of the Water Supply (Water Fittings) Regulations 1999.

Valves approved for designation of use LP Tub applications that only achieve the minimum flowrate requirement at a supply pressure of 0.2 bar must indicate that the minimum supply pressure for LP Tub application is 0.2 bar.

RECOMMENDED OUTLET TEMPERATURES

The BuildCert TMV scheme recommends the following set maximum mixed water outlet temperatures for use in all premises:

Application	Recommended Set Mixed Water Temp
Wash Hand Basin	41°C
Shower	41°C
Bidet	38°C
Bath Fill	44°C

The mixed water temperatures must never exceed 46°C, The maximum mixed water temperature can be 2°C above the recommended maximum set outlet temperatures.

NOTE: 46°C is the maximum mixed water temperature from the bath tap. The maximum temperature takes account of the allowable temperature tolerances inherent in the thermostatic mixing valves and temperature losses in metal baths. It is not a safe bathing temperature for adults or children.

The British Burns Association recommends 37°C to 37.5°C as a comfortable bathing temperature for children. In premises covered by Care Standards Act 2000, the maximum mixed water outlet temperature is 43°C

INSTALLATION

IMPORTANT - The following instructions must be read prior to the installation of a The BOSSMIX range of thermostatic mixing valves The installer should also be aware of their responsibility and duty of care to ensure that all aspects of the installation comply with all current regulations and legislation.

It has been brought to our attention that flushing through water systems using certain chemicals may wholly or partially remove the lubricant from the internal workings of the valve, which may adversely affect its performance. We recommend that following flushing of the system with chemicals; valves are checked for correct operations.

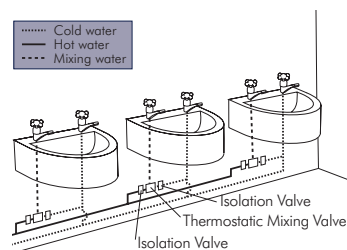

The BOSSMIX range of thermostatic mixing valves MUST be installed in an accessible position to ensure that maintenance, commissioning and testing of the BOSSMIX RANGE OF THERMOSTATIC MIXING VALVES can be undertaken easily.

- It is essential that before installing any of the BOSSMIX range of thermostatic mixing valves ensure that the supply conditions of the system to which the valve is intended to be fitted are checked to confirm compliance with the parameters as quoted within the technical specification and conditions on which the approval is granted i.e. verify supply temperatures, supply pressures, risk assessment.
- Consideration must be made for the possibility of multiple / simultaneous demands being made on the supply system whilst the BOSSMIX range of thermostatic mixing valves is in use, all practical precautions must be made to ensure that the valve is not affected. Failure to make provision within the pipe sizing etc. will affect the performance of the valve.
- The supply system to which the BOSSMIX range of thermostatic mixing valves valve is to be installed into must be thoroughly flushed and cleaned to remove any debris, which may have accumulated during the installation. Failure to remove any debris will affect the performance and the manufacturer's warranty of the product. Independent filters / check valves and isolation valves must be fitted in conjunction with the valve. In areas that are subject to aggressive water, provision must be made to treat the supplies prior to the supplies entering any INTA product.
- The maximum flow rate of the valve will only be achieved when the supply conditions are achieved as quoted within the technical specification, with a flow condition under 1 bar differential pressure.
- The BOSSMIX range of thermostatic mixing valves has been designed to ensure that the valve can be installed in any position whether vertical or horizontal, it can be surface mounted or within a supply duct. It is essential that the access to the valve not be obstructed for any future maintenance that may be required to the valve or associated fittings.
- We recommend that the BOSSMIX range of thermostatic mixing valves fail-safe thermostatic mixing valve be installed as close as practically possible to the outlet, which it is serving. In this situation attention must be paid to the maximum distance of pipe work from the mixed water outlet of the valve to any terminal fitting.
- Current guideline recommended a maximum distance of 2m from the outlet of any mixing valve to the furthest terminal fitting / outlet to which the mixing valve is to serve.
- The hot and cold water supplies must be connected to the valve strictly in accordance with the indications on the body of the valve i.e. hot water supply to the hot port of the valve.
- In a situation where one or both of the water supplies are excessive, it is possible to fit a pressure reducing valve to reduce the pressure(s) to within the limits as quoted previously.
- Any thermostatic mixing valve must be fitted with a back flow prevention device, such as check valves to prevent the cross contamination of supplies. The BOSSMIX range of thermostatic mixing valves is complete with integral insert check valves and strainers.
- We recommend that Y Pattern strainers and full-bore isolation valves are installed in conjunction with the BOSSMIX range of thermostatic mixing valves fail safe products – the Y Pattern Strainers should be fitted as close a practically possible to the valve. Alternatively the use of the AC optional tail pieces removes the need for additional filters and isolation valves.